

# *velocino*

## User Manual

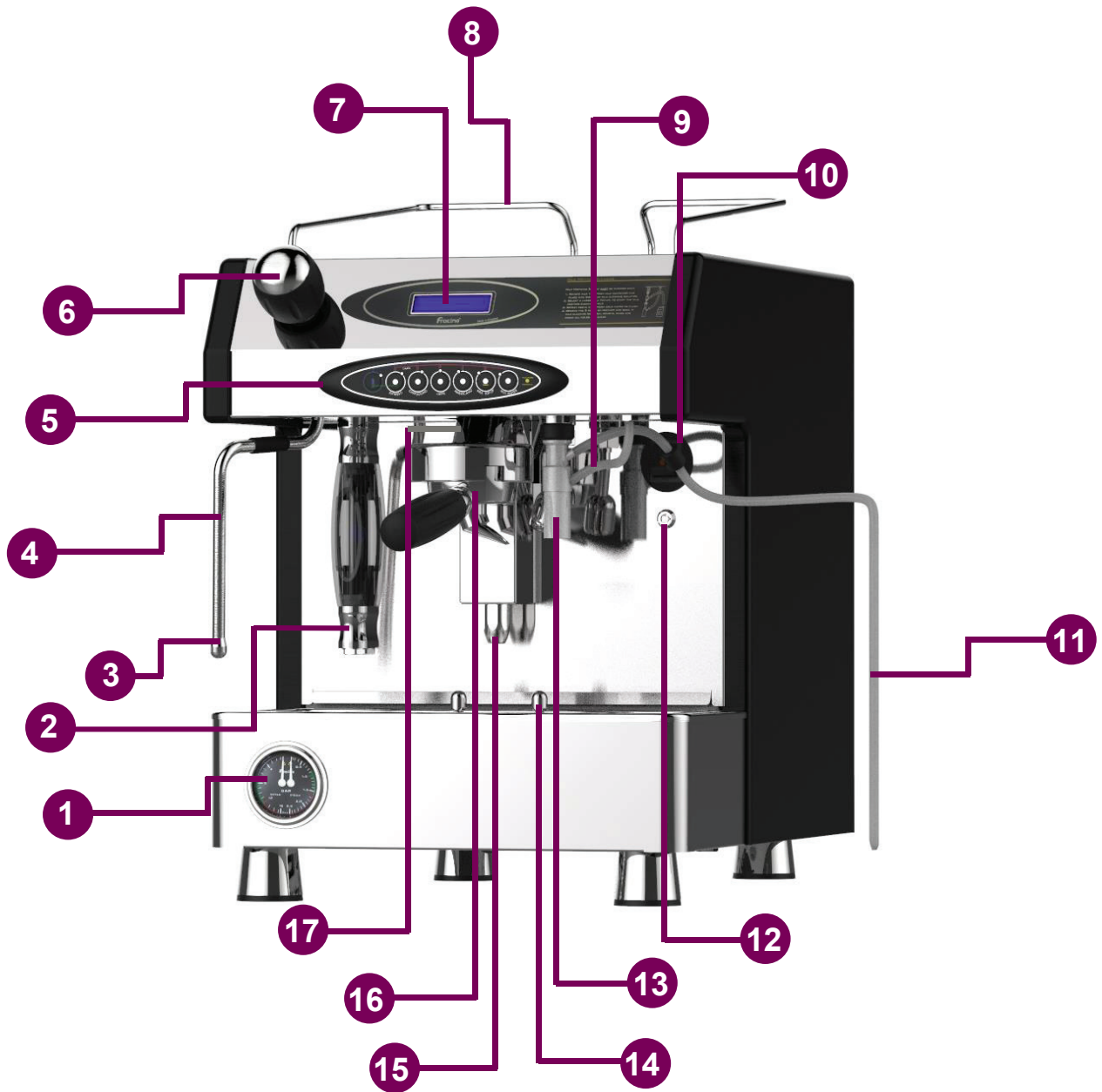

# MACHINE OVERVIEW



**1** Pressure Gauge

**2** Sight Glass

**3** Steam Tube Nozzle (if fitted)

**4** Steam Tube (if fitted)

**5** Keypad

**6** Steam Valve Handle (if fitted)

**7** LCD Display

**8** Cup Shield (if fitted)

**9** Air/Steam Inlet Tube

**10** On/off Switch

**11** Milk Inlet Tube

**12** Programming Key Switch

**13** Milk Frother

**14** Cup Positioning Pins

**15** Group Exhaust

**16** Filter Holder

**17** Group

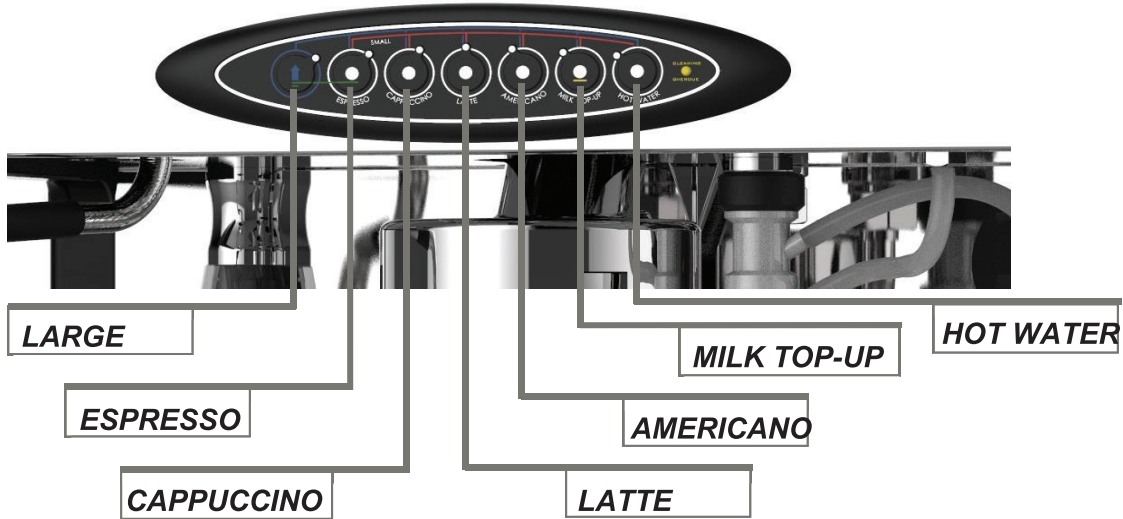

## KEYPAD - DETAIL

| PRIMARY FUNCTIONS  |   |
|--------------------|---|
| <b>LARGE</b>       | Press before selecting drink to dispense a large drink, the drink must be selected within 5seconds. |
| <b>ESPRESSO</b>    | Dispenses a shot of Espresso  |
| <b>CAPPUCCINO</b>  | Dispenses a Cappuccino  |
| <b>LATTE</b>       | Dispenses a Latte   |
| <b>AMERICANO</b>   | Dispenses an Americano  |
| <b>MILK TOP-UP</b> | Dispenses a small amount of steam milk  |
| <b>HOT WATER</b>   | Dispenses a measured dose of hot water  |

**NOTE:** See Making drink section for details on making drinks

**NOTE:** Drinks can be cancelled at any time by pressing any button during the dispense cycle.

**SECONDARY FUNCTIONS** CLEANING**LARGE AND ESPRESSO TOGETHER**

Starts the group cleaning cycle, see cleaning section, for full instructions on cleaning the group.

**LARGE THEN MILK TOP-UP**

Starts the milk frother cleaning cycle, see cleaning section, for full instructions on cleaning the milk frother

**NOTE:** The milk frother and group must be cleaned as instructed

**PROGRAMING MODE**

The programming key is required to enter program mode

**ESPRESSO AND LATTE TOGETHER AND HOLD FOR 5 SECONDS**

Enters the drink timing menu, where milk and water times can be adjusted, see technical section for details

**ESPRESSO AND AMERICANO TOGETHER AND HOLD FOR 5 SECONDS**

Enters the technical menu, where machine settings such as the clock and automation on/off feature can be adjusted, see technical section for details

**ESPRESSO AND HOT WATER TOGETHER AND HOLD FOR 5 SECONDS**

Enters the Espresso shot programming mode, where espresso shot volume for each drink can be set, see technical section for details

**ESPRESSO AND CAPPUCCINO TOGETHER AND HOLD FOR 5 SECONDS**

Enters the Drinks counters menu, use the Milk Top-up button to scroll, see technical section for details.

**NOTE:** Machine and drink settings can be adjusted in the programming menu, it is recommended that only trained persons make adjustments to the machine.

**STAND-BY MODE****LARGE AND LATTE TOGETHER**

Turns the stand-by mode off and on,

**NOTE:** When the machine has been turned to stand-by mode, the heating element and drink functions are disabled, but power is still going to the machine.

**NOTE:** If the automatic on/off feature is selected the machine will go in to stand-by mode when it turns off, the machine can be turned on at any time by pressing the LARGE and LATTE as described above.

# START UP

**NOTE:** Ensure machine has been correctly installed by a suitably trained engineer, see Fracino Installation manual for details on installing the machine.

1. Ensure the machines power and water supply has been turned on.
2. Turn the machine on using the power switch on the front panel.

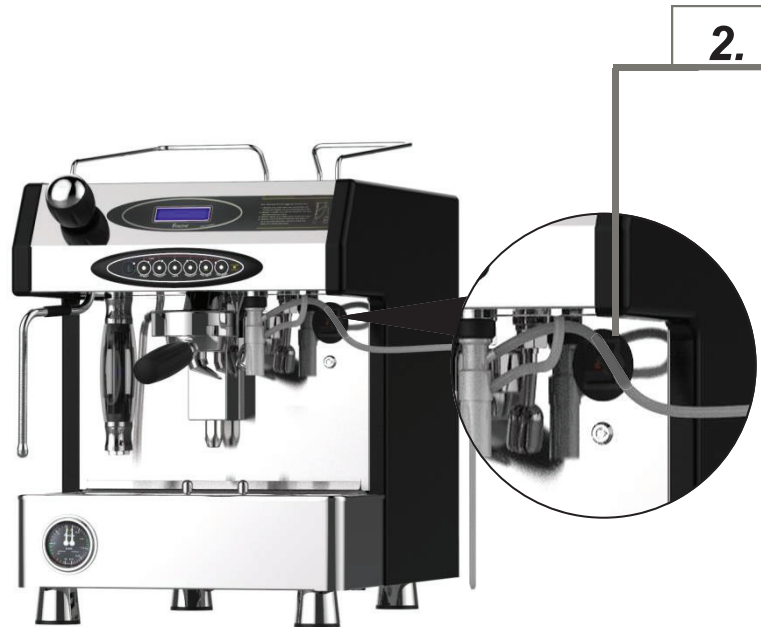

3. The machine will take approximately 8-10minutes to heat up, the progress of the heating will be indicated on the display.
4. During the heating cycle, steam will vent from the milk frother a couple of times.

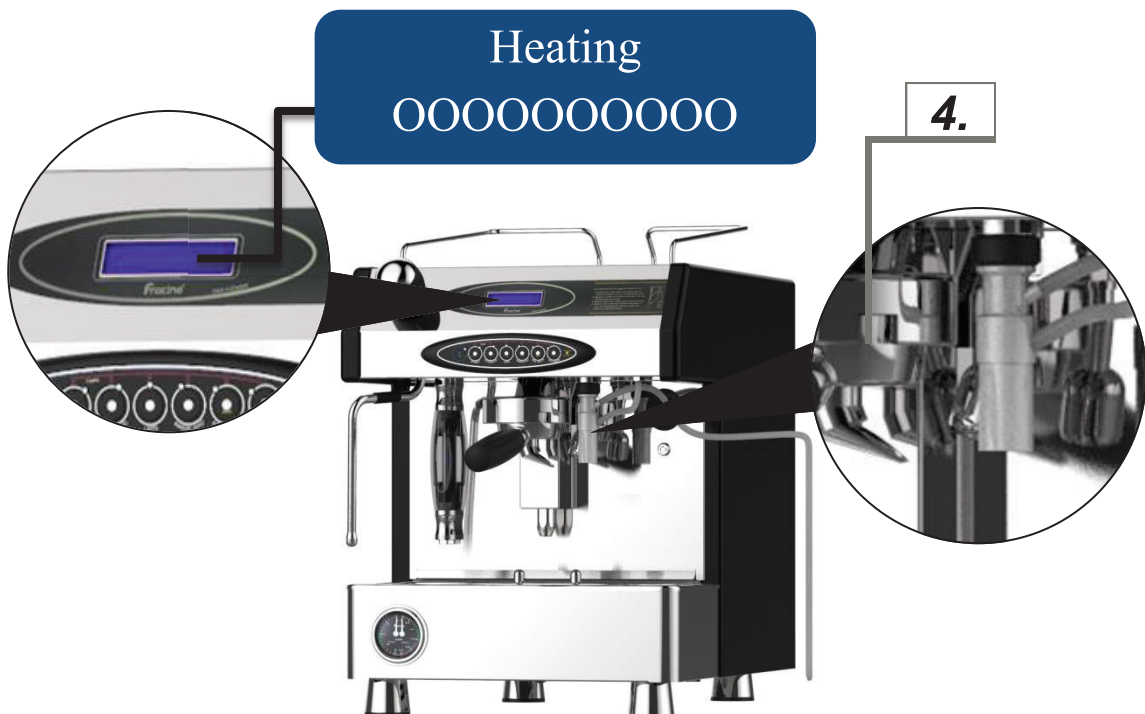

5. After approximately 8-10mins the display will show, the boiler temperature, time and “select drink”, the machine is now ready to use



6. The steam pressure is located on the right hand side of the pressure gauge, this should read between 1.0 and 1.3Bar, when the machine is up to temperature.



**WARNING:** If the pressure gauge reads above 1.5Bar, the machine should be turned off and isolated from the mains power supply and a suitably trained engineer should be called to inspect, repair and test the machine.

**NOTE:** It is recommended that the machine is left to stand for about 15minutes before making drinks. This will allow the group to heat thoroughly, which will the machine to produce coffee at the correct temperature.

## MAKING DRINKS



**WARNING:** Drinks from the machine are hot, take care to avoid scalding



**WARNING:** Do not allow untrained persons to operate the machine



**WARNING:** To reduce the risk of scalding, do not hold the cup whilst a drink is dispensing

**NOTE:** For milk based drinks the milk frother inlet tube must be completely immersed in fresh, cold milk - milk fridges are available from Fracino.



**WARNING:** It is the users responsibility to ensure milk is kept cool (0-6°C) and only fresh milk is used, failure to do so may result in poor performance and also create a health hazard. Milk fridges are available from Fracino.



**WARNING:** It is the users responsibility to ensure the milk frother is cleaned at least once a day and is kept clean, failure to do so may reduce the performance of the frother and may result in a health hazard, see cleaning section for cleaning instructions.

**NOTE:** Due to natural variations in milk, it is sometimes not possible to froth milk correctly, try a new batch or brand before adjusting settings.

### MAKING ESPRESSO BASED DRINKS

1. Select either a single or double filter holder.
2. Fill the filter holder with fresh ground coffee.

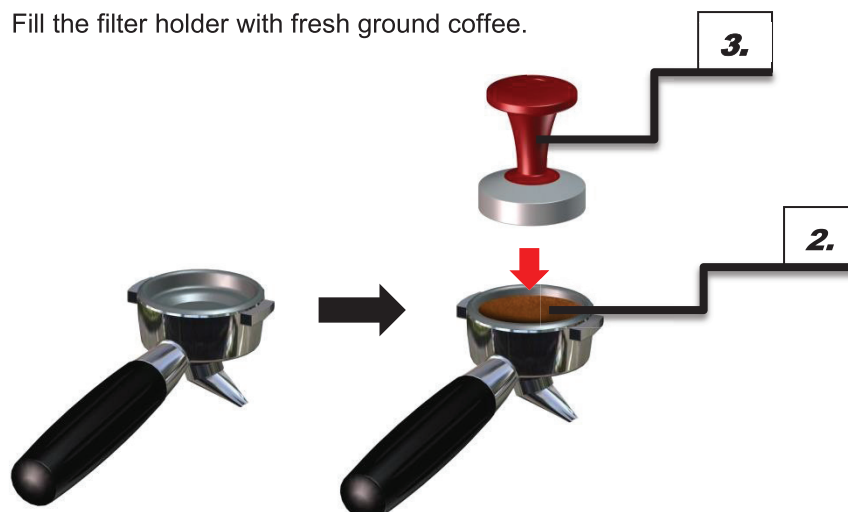

3. Compress and level the ground coffee with a tamp, the machine comes supplied with a plastic tamp (the image above is not representative of the plastic tamp)

**NOTE:** The freshness of coffee, coarseness of the grind, the tamping pressure, amount of ground coffee used will affect the quality of the extraction of the espresso shot, operator training maybe required to achieve best results

**NOTE:** Fracino offer a range of adapters and conversion kits to allow the machine to use coffee PODs and Capsules, contact Fracino for further information.

4. Offer the filter holder up to the group, line up the lugs on the filter holder with the notch on the side of the group.

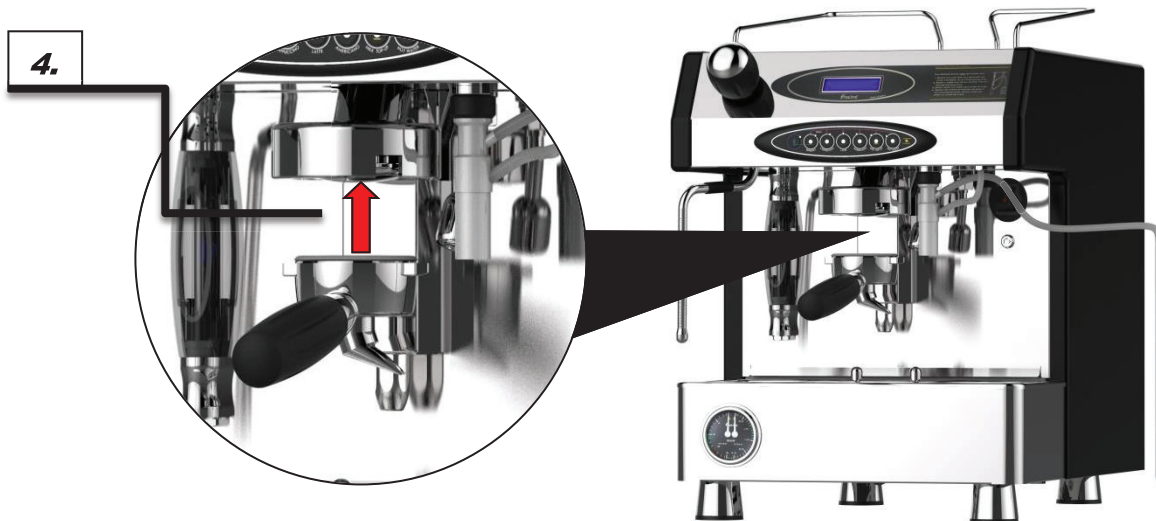

5. Firmly turn the filter holder anti-clockwise, until the handle of the filter holder is pointing towards you.



- 6. Place a cup under the group, the positioning pins on the drip tray grid should be used to ensure the cup is in the correct position.

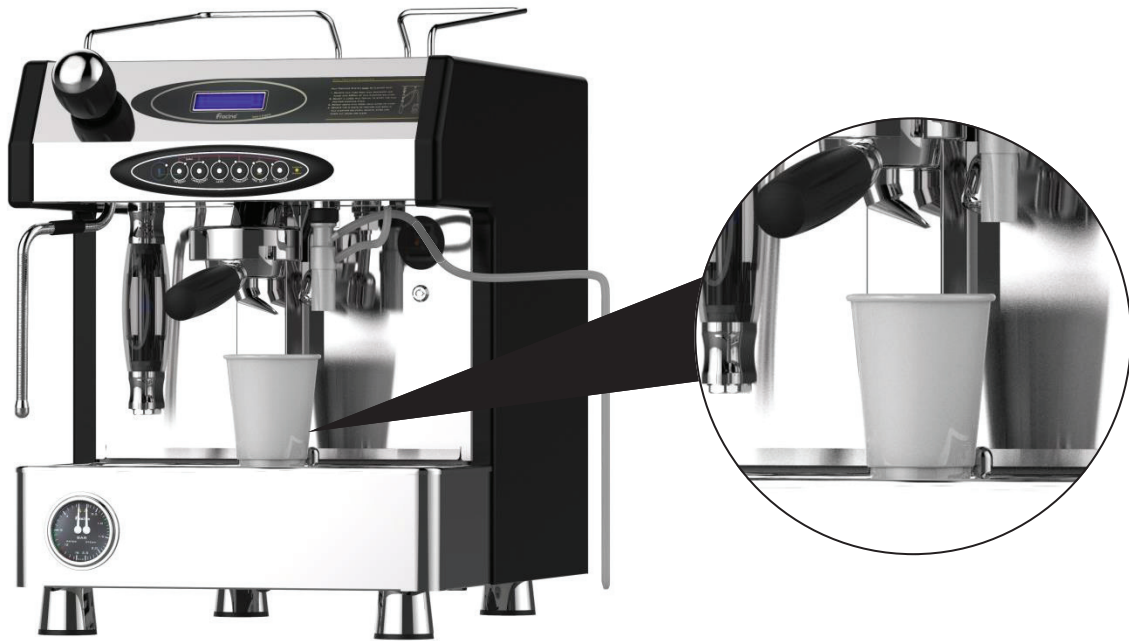

- 7. Select the require drink by pressing the appropriate button, pressing the large button before pressing the drink button will dispense a large drink.



- a. ESPRESSO** – a shot of espresso is dispensed
- b. CAPPUCINO** – a shot of espresso is dispensed together with a timed dose of cappuccino milk
- c. LATTE** – a shot of espresso is dispensed together with a timed dose of latte milk
- d. AMERICANO** – a shot of espresso is dispensed together with a timed dose of hot water

- 8.** The display will indicate the drink that is getting dispensed and also the progress of the drink.



- 9.** At the end of the drink cycle the display will read “Select Drink”. Remove the filter holder and knock out the used coffee in to a waste container.

**NOTE:** When a milk drink cycle has finished the milk frother will pulse steam 3 times to clean the system.

**NOTE:** Drink times and volumes can be adjusted in the drinks programming menu, see technical section

#### **MILK TOP-UP**

- 1.** The milk top-up is used to add a small amount of milk to a drink. For example to adding milk to an Americano to make a white coffee. It can also be used to top-up a latte or cappuccino if the drink volume is low.
- 2.** Selecting a large milk top-up will start the cleaning cycle, see cleaning section.

## **HOT WATER**

- 1.** The hot water button is used to dispense a timed dose of hot water, the timing can be adjusted in the programming menu.
- 2.** Selecting a large hot water will dispense a larger dose of hot water, depending on the programmed setting.



**WARNING: DO NOT** hold the cup whilst the machine is dispensing drinks. The hot water from the coffee machine is hot and can scald

## MANUALLY STEAMING MILK

1. Open the steam valve, by turning the steam handle anti-clockwise, for a second or two to vent the system, then close the valve.
2. Fill a stainless steel milk jug approximately 1/3 full with fresh cold milk.

**NOTE:** Ensure fresh cold milk is used, do not try to re-steam milk

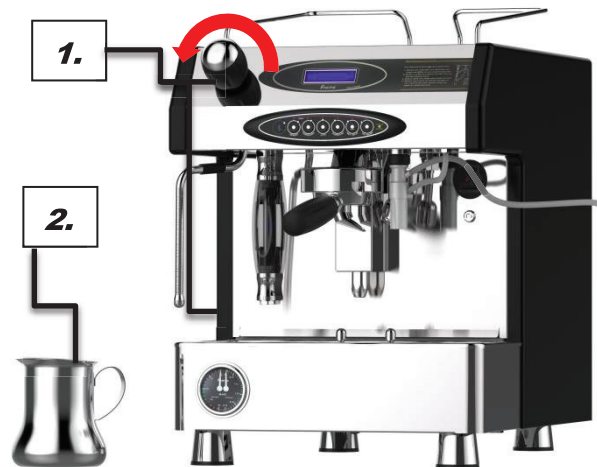

3. Place the milk jug into the steam tube, ensuring the tip of the steam tube is in the milk.
4. Open the steam valve fully, then lower the milk jug so the steam nozzle is just at the surface of the milk, this will draw in air which will foam the milk, to make cappuccinos. Raising the milk jug will put the nozzle deeper in the milk stopping air entering the milk, which will steam the milk, for Lattes.

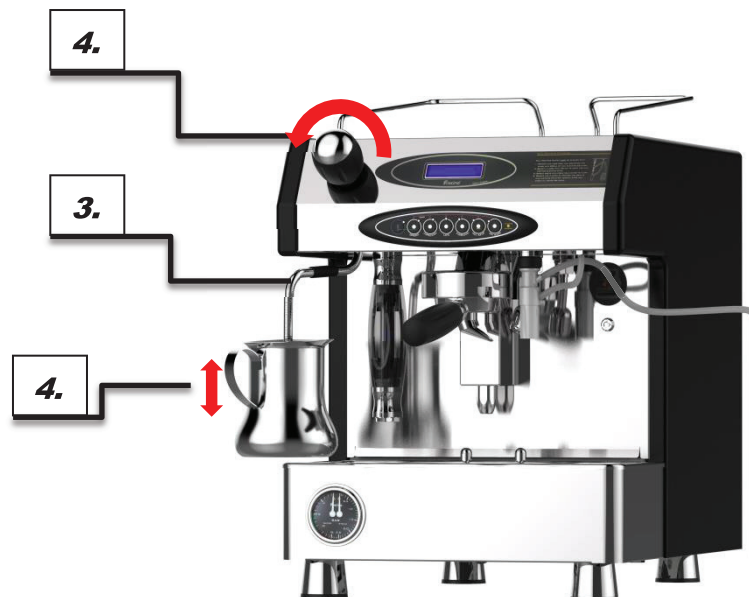

5. When the milk is at the required temperature (65-70°C) and consistency, close the steam valve.

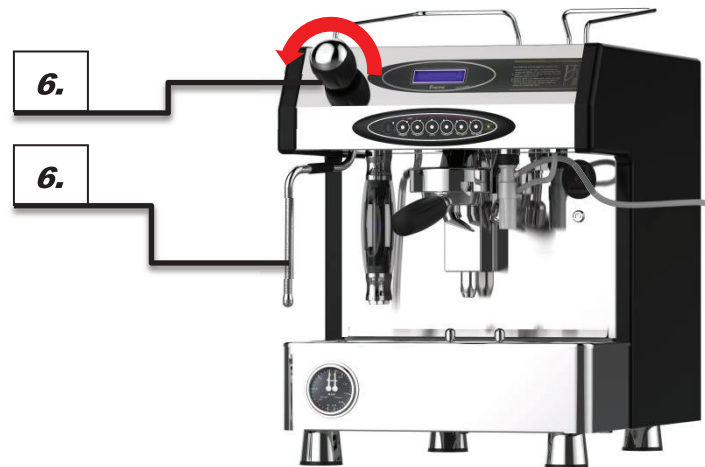

**NOTE:** A milk thermometer can be used to measure the milk temperature while steaming milk, these are available from Fracino

6. After steaming milk, open the steam valve for a second or two, which will help to keep the holes in the nozzle clear. Wipe the steam tube with a damp cloth, to remove any milk residue



**WARNING:** The steam tube, milk jug and milk will become hot, take care to avoid scalding.

**NOTE:** Natural variations in milk can prevent it from being steamed and frothed correctly, if this occurs try fresh milk or a different brand.

**NOTE:** Steaming and frothing milk requires a certain amount of skill and practice, it is recommended that adequate training and practice is given to users.

## CLEANING

### Daily Group Cleaning

1. The group must be cleaned daily to maintain best performance
2. Remove the filter holder from the group, using a showerplate brush clean the underside of the group and around the filter holder washer (showerplate brushes can be obtained from Fracino – part no. FC54)
3. Press the espresso button to dispense water from the group, repeat 4-5 times.
4. Load a blank filter holder in to the group, special colour coded handles (as shown) are available from Fracino

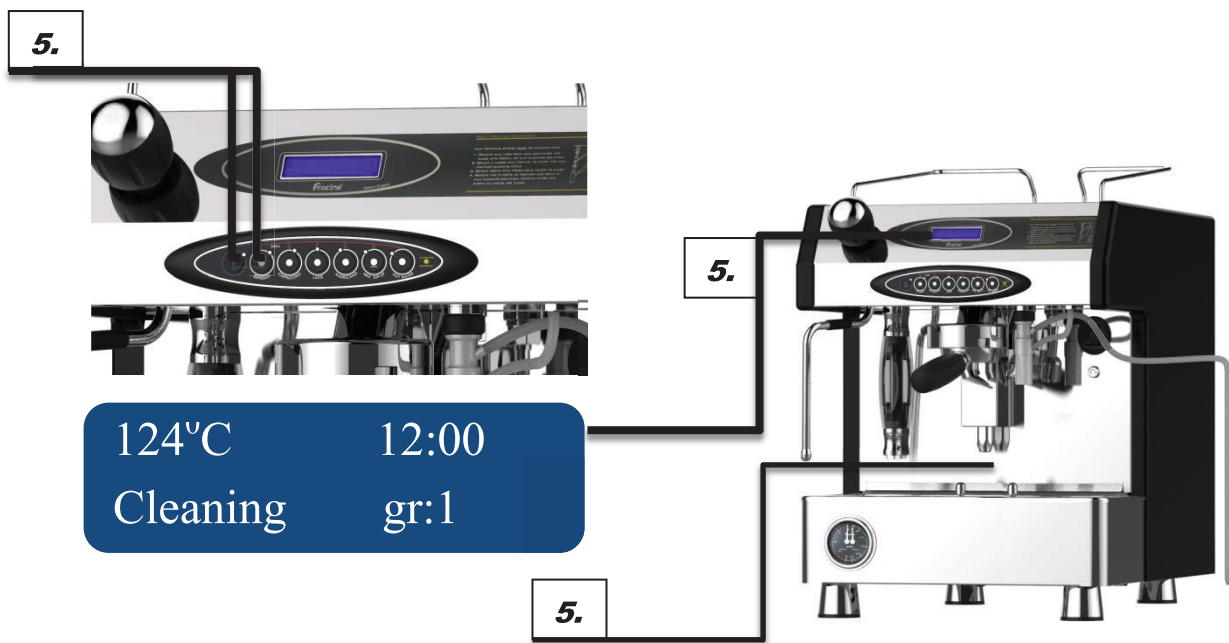

5. Press the Large and Espresso buttons at the same time to start the group cleaning cycle, the display will read "CLEANING GR1" the group will pulse several times, at the end of each pulse dirty water will exhaust from the group exhaust.
6. When the cleaning cycle has finished remove the filter holder and empty the contents of the blank filter. Repeat steps 4-6 if required.

### Weekly Group Cleaning

1. At least once a week, or more frequently with heavy use, the group should be thoroughly cleaned using Fracino Liquid Quartz cleaning liquid (available from Fracino).
2. Remove the filter holder dip the shower plate brush in some neat Liquid Quartz and clean the underside of the group and filter holder washer, the liquid quartz will help remove stubborn coffee residue.
3. Press the espresso button to dispense clean water from the group, repeat until all quartz has been rinsed away, use a clean shower plate brush to help rinse quartz from the filter holder washer.
4. Put a ¼ cap of liquid quartz in to the blank filter holder and lock in to group.

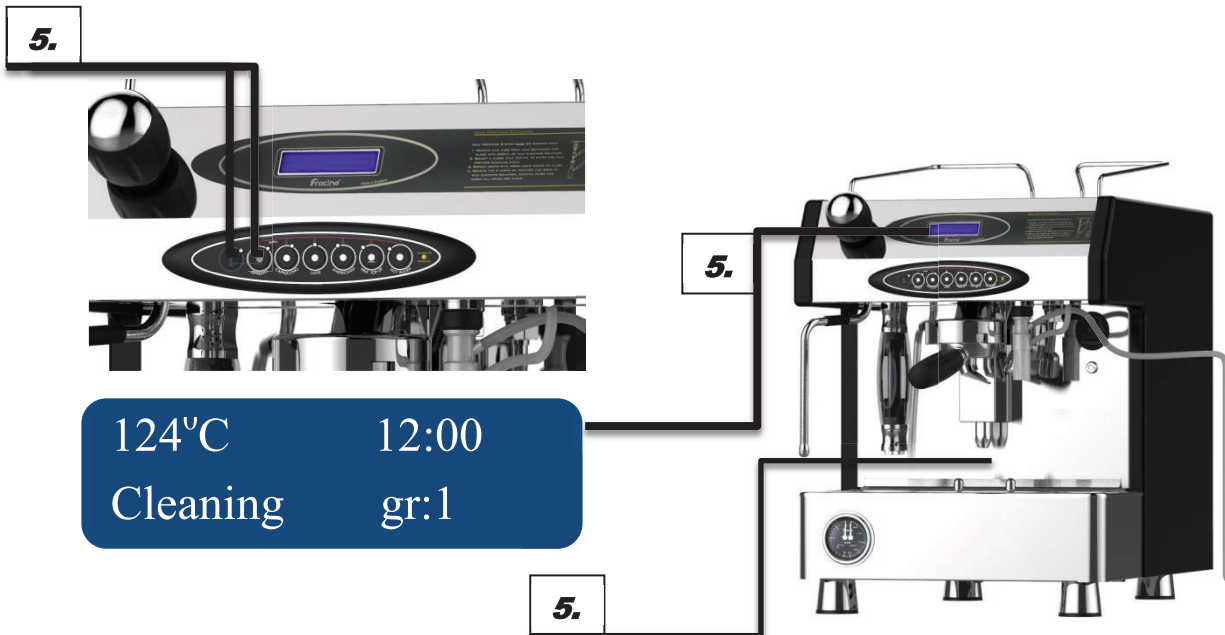

5. Press the Large and Espresso button at the same time to start the group cleaning cycle, the display will read "CLEANING GR1" the group will pulse several times, at the end of each pulse dirty water will exhaust from the group exhaust.
6. When the cleaning cycle has finished remove the filter holder and empty the contents of the blank filter. Repeat steps 4-6 several times WITHOUT Liquid Quartz to flush any remaining quartz residue.

### Milk Frother Cleaning

1. The Milk frother should be cleaned at least once a day, or more frequently with heavy usage to ensure the best performance and maintain good hygiene standards.
2. Make some of cleaning solution, using 500mL of fresh cold water and 25mL (approx. 3 cap fulls) of Fracino milk frother cleaning liquid.
3. Place the milk inlet tube into the cleaning solution and place a container under the milk frother spout.



4. Select a Large Milk Top-up to start the milk cleaning cycle, the milk cleaning cycle will take approximately 60seconds.





5. When the cycle has finish, retain the warmed cleaning solution that has come from the frother. This will be used in step 8.
6. When the cycle has finish, remove the milk inlet tube and steam/air tube from the milk frother

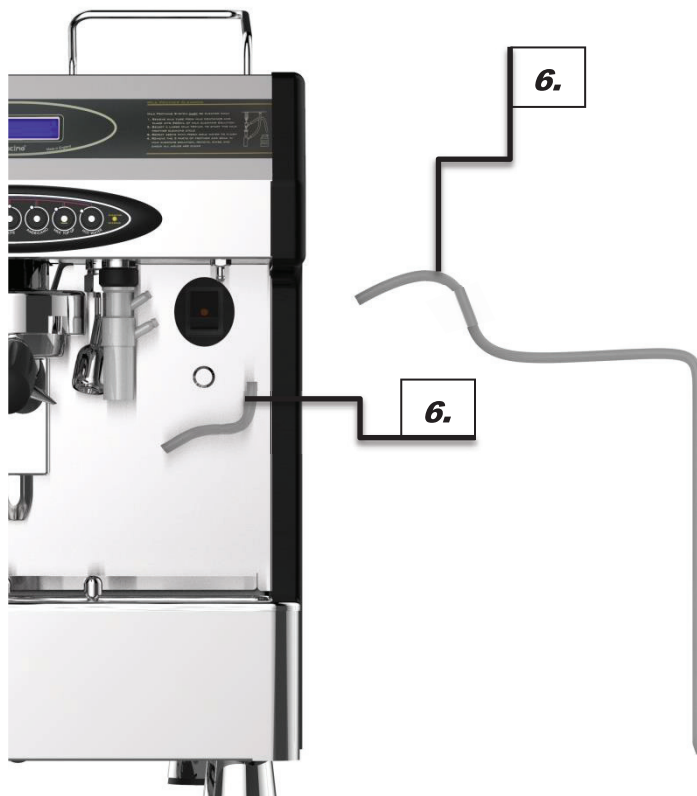

7. Dis-assemble 3 white components of the milk frother, as shown.
8. Place all the milk frother components in to the warmed milk cleaning solution and allow to soak overnight, or at least an hour.

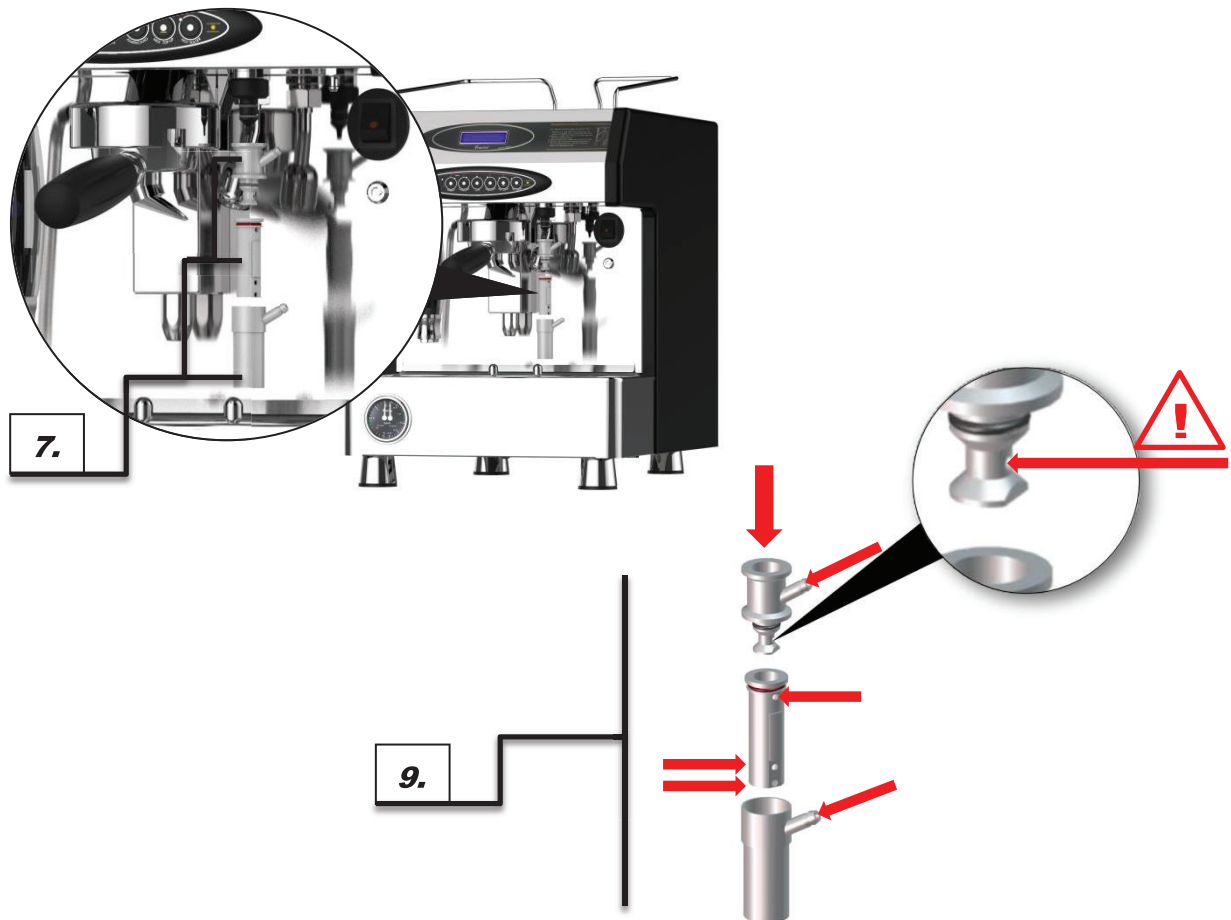

9. Remove the components from the milk cleaning solution, inspect all components paying special attention to the holes. Ensure all holes are completely clear of milk residue, the cleaning brushes can be used for this purpose.
- 10. Thoroughly rinse all of the milk frother components in fresh water.**
11. Inspect the nozzle, wipe any milk residue with a soft damp cloth, if heavy congealed, remove the nozzle by unscrewing it, taking care not to lose the red o-ring, and allow to soak in milk cleaning solution overnight – **ensure part is thoroughly rinsed in fresh water before re-fitting.**

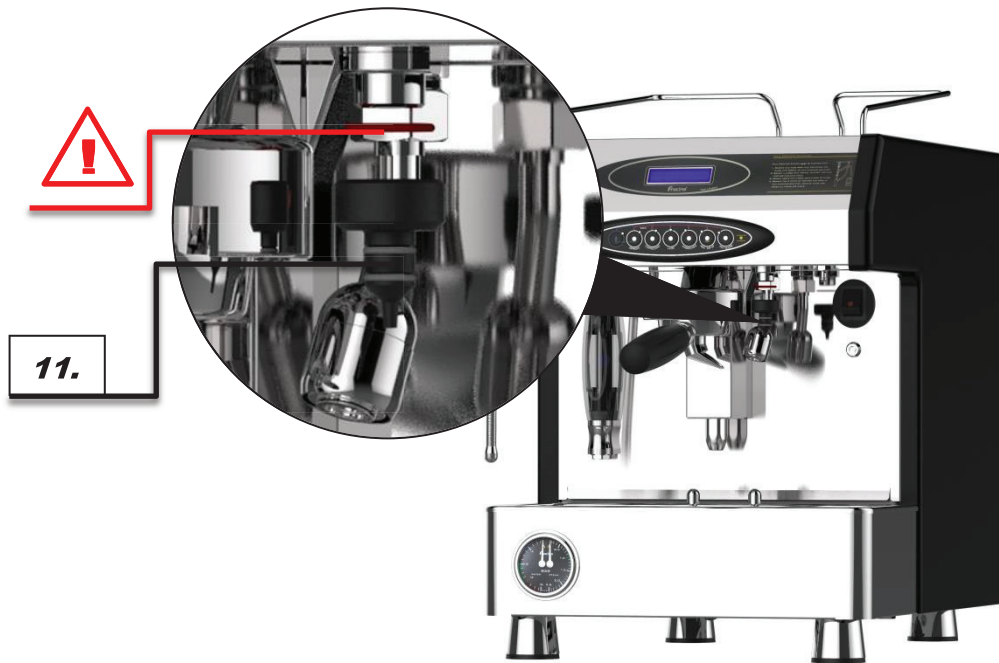

- 12.** Re-assemble all parts, ensuring all o-rings are present, and all parts are in the correct orientation and are firmly fitted together. Check the milk inlet tube and steam/air tube are in the correct orientation.

### **General Cleaning Procedures**

- 1.** The machine should be cleaned and wiped down daily.



**WARNING:** Do not use bleach based cleaners to clean any parts of the machine, doing so will damage the stainless steel finish.



**WARNING:** Use only a soft damp cloth to clean the machine, do not use a scouring pad, doing so will damage the stainless steel and painted finishes.



**WARNING:** Do not immerse the machine in water to clean, or clean using a water jet.

2. Remove the drip tray and drip tray grid, clean with warm water, a mild detergent and a soft cloth.



3. Remove the filter holder(s) from the group and clean with warm water and a mild detergent, if heavy soiled with coffee residue or a thorough clean is required, soak the filter holder in a quartz cleaning solution and wipe clean using a soft cloth, **rinse thoroughly rinse with fresh water.**
4. Wipe the outer case with a soft damp cloth.

# PROGRAMMING

## Programming – Espresso and Hot Water Volumes

1. For each drink the volume of espresso can be set within the programming menu.

**NOTE:** Some suggested espresso and hot water volumes can be found in the appendix of this manual.

2. Enter the programming mode using the programming key.
3. The display will read “Programming” when the machine is in programming mode.

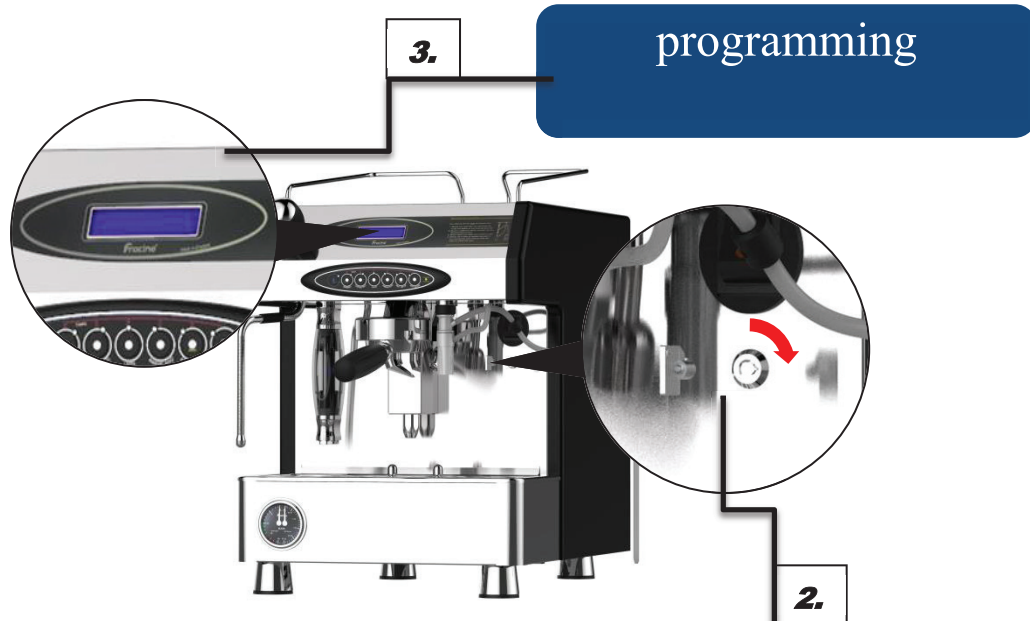

4. Press and hold the Espresso and Hot Water buttons together for 10seconds, until the display reads “Program within 30 seconds”
5. Prepare the filter holder, as described on page 3, press the espresso, button to start brewing a drink – only the espresso will be dispensed when in programming mode. When the desired volume of coffee has been dispensed press the espresso button again to stop the flow of coffee. Repeat for the cappuccino, latte and Americano, large espresso, Large Cappuccino, Large latte and Large Americano.

**NOTE:** It is recommended that fresh coffee is used, for programming each drink, this helps to program espresso volumes more accurately.

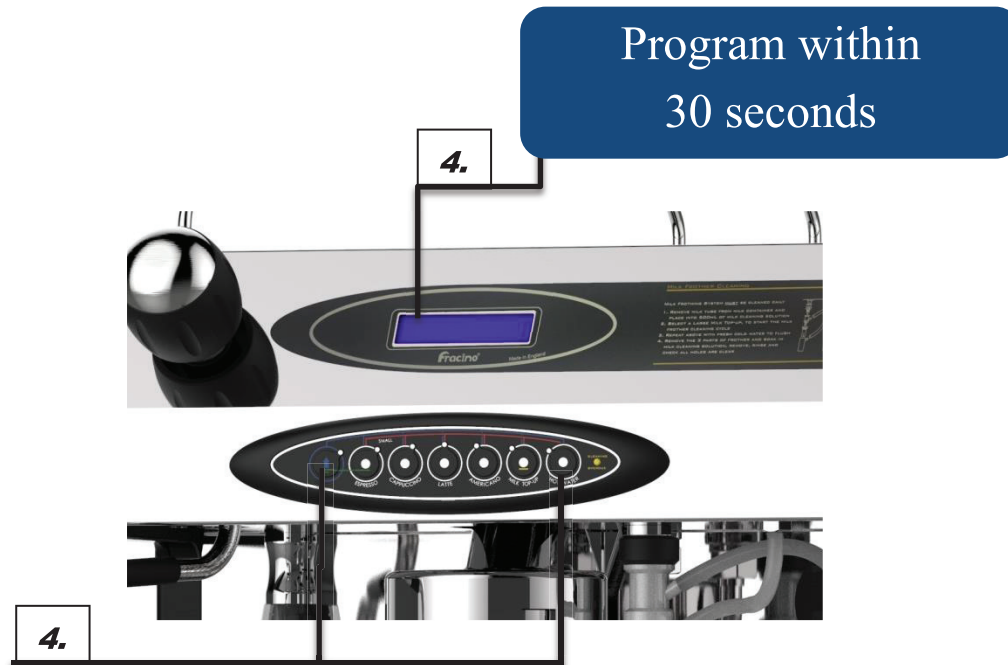

- 6.** To program the Hot water volume, place a cup or measuring jug under the hot water spout and press the hot water button, when the desired volume has been dispensed press the hot water button again to stop the flow, repeat for Large hot water.

**NOTE:** The Hot water volume is programmed using time, unlike the espresso which is measured using a flow meter. The Hot water volume may vary slightly during use.

- 7.** When all espresso and hot water volumes have been programmed, remove the programming key to come out of the programming mode.

### Programming – Drink Times

1. The hot water and milk times for each drink can be tailored to create the required Cappuccino, Latte and Americano.
2. Enter the programming mode using the programming key.
3. The display will read “Programming” when in programming mode

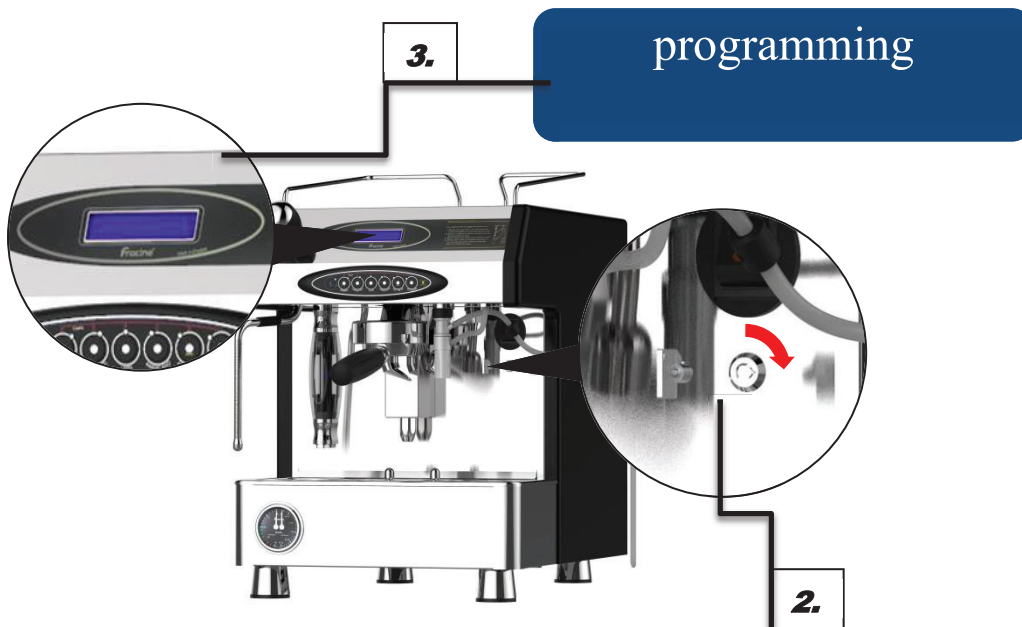

4. Press and hold the Espresso and Americano buttons together for 10seconds, until the display read “Time Program Select Drink”.



5. Select the drink you require to change, for example Cappuccino, use the Latte button to scroll through the drink settings.

**NOTE:** Some suggested drink times can be found in the appendix

6. Use the Espresso and Cappuccino buttons to increase or decrease the times.
7. Repeat for other drinks as required.

**NOTE:** In order to save the settings, you must scroll through all of the drink settings until the display reads “Time Program Select Drink”

8. Remove the programming key to come out of programming mode.

### **Programming – Technical Menu**

1. The Technical Menu is where machine setting can be changed.
2. Enter the Programming mode using the programming key.
3. The display will read “Programming” when in programming mode.

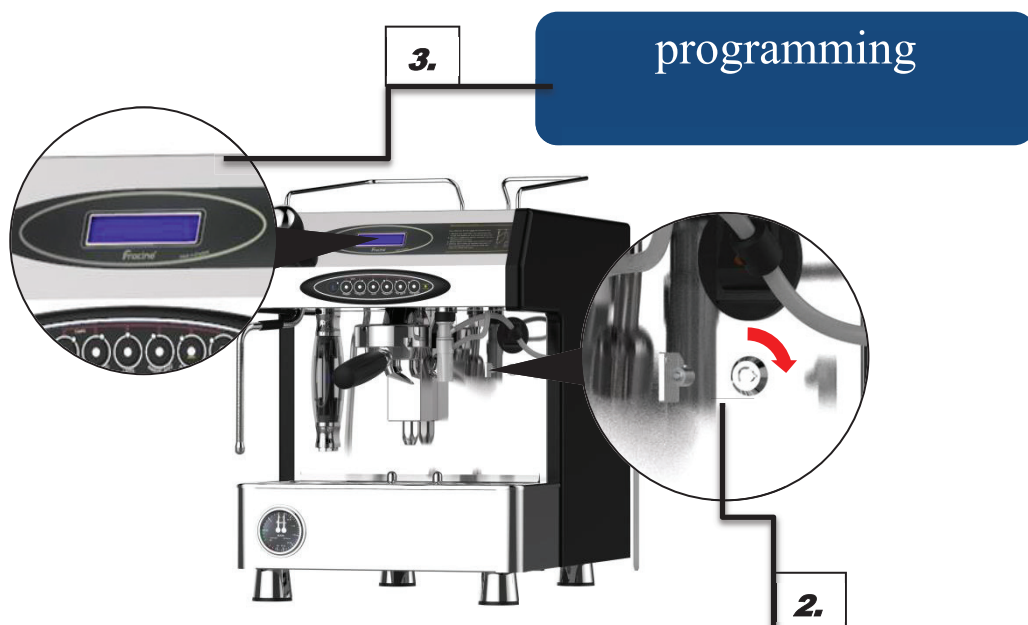



4. Enter the Technical menu by pressing and holding the Espresso and Milk Top-up Buttons together for 10 seconds until the display reads "Language: English"

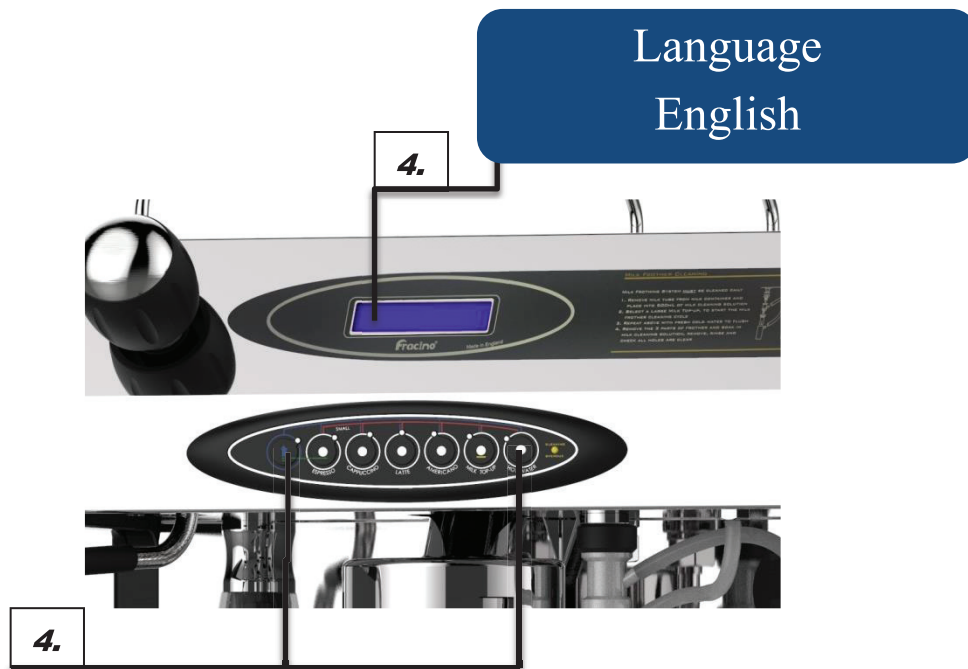

5. Use the Latte button to scroll through the different settings and the Espresso and Cappuccino button to change the setting, listed below is definition of each setting.

Language  
English

**Language:** select between English, French, German and Italian.

Buzzer  
Enable

**Buzzer:** Enables or disables the audible buzzer, that sounds when buttons are pressed or when an alarm is detected

Milk topup  
Latte

**Milk Top-up:** Selects the type of milk to be dispensed when a Milk Top-up is selected, either Cappuccino or Latte

Water filter  
5000

**Water Filter Limit:** This indicates the amount of water, in litres, that can pass through the machine before the water filter needs replaced, when this value is reached it will be indicated on the display. The water hardness will determine how much water can flow through before the water filter needs replaced.

Service cycles  
30000

**Service Cycles:** Selects the number of drinks dispensed before the machine should be serviced. Servicing is recommended at least once a year.



**WARNING:** The service counter is only an indication of when the next service is due, services maybe required more often depending on usage, water hardness etc... **It is also a legal requirement under the HSE PSSR Act of 2002 to have the boiler inspected and tested annually**, contact Fracino or an authorised service agent for further information or to have your boiler tested. A Written Scheme of Examination is available in the supplied installation manual. **The service counter is not an indication of when the boiler is due for an inspection or service.**

Tea+pump  
enabled

**Tea and Pump:** This selects if the pump is activated when hot water is dispensed. This should be set to **Enabled**.

Clock adjust  
12:00 Monday

**Clock Adjust:** Sets the time and day, use the Latte button to cycle through the digits and the Espresso and Cappuccino buttons to increase or decrease the values.

Auto on/off  
On: 7:00

**Auto on/off:** Sets the on time for the automatic on/off feature. Use the Latte button to cycle through the digits and the Espresso and Cappuccino buttons to increase or decrease the values. Select "--/--" to disable the feature.

Auto on/off  
off: 7:00

**Auto on/off:** Sets the off time for the automatic on/off feature. Use the Latte button to cycle through the digits and the Espresso and Cappuccino buttons to increase or decrease the values. Select "--/--" to disable the feature.

**NOTE:** When the automatic on/off feature is activated the machine will go in to standby mode. Refer to page XXX for details about the standby mode.

Closed on  
sunday

**Closed on:** When the automatic on/off feature is activated, a day can be selected where the machine will not come on at all, for example if Sunday is selected, the machine will turn off on Saturday night and come back on Monday morning.

name  
fracino

**Name:** Allows the owner/user to give the machine a reference name, use the Latte button to cycle through the characters and the Espresso and Cappuccino to change the character.

groups

1

**Groups:** Selects the number of groups, this should be set to 1.

LED Idle

enabled

**LED Idle:** When selected to Disabled the LEDs on the keypad will illuminate all of the time, when set to Enabled the LEDs will be off and will flash when a drink is selected. The default setting is Enabled.

Fillingup+coffee

enabled

**Filling up and Coffee:** When enabled drinks can be dispensed when the boiler is filling. When disabled is selected

Probe sensitivity

mid

**Probe Sensitivity:** Sets the sensitivity of the boiler level probe.

Temperature

enabled

**Temperature:** When enabled, if the temperature boiler temperature drops below 120°C, the machine will not allow drinks to be made until the boiler is back to the correct temperature, this is to ensure drinks are made to the best quality.

Temperature

°C

**Temperature °C/°F:** Select if the temperature on the display reads in °C or °F.

### Programming – Technical Menu

1. The machine records the amount of drinks that have been dispensed, the amount of water used and total number of drinks.



2. When in programming mode press and hold the espresso and cappuccino together for 5 seconds until the display reads “DRINK COUNTER”.
3. Use the Milk top-up button to scroll through the various counters
4. To re-set the counters, scroll through the counters until the display reads “DOSES TOTAL”. Press and hold the Latte and Americano buttons until the display reads “DOSES TOTAL, TOTALS RESET”. This re-sets the individual drink counts but not the total drink counter.

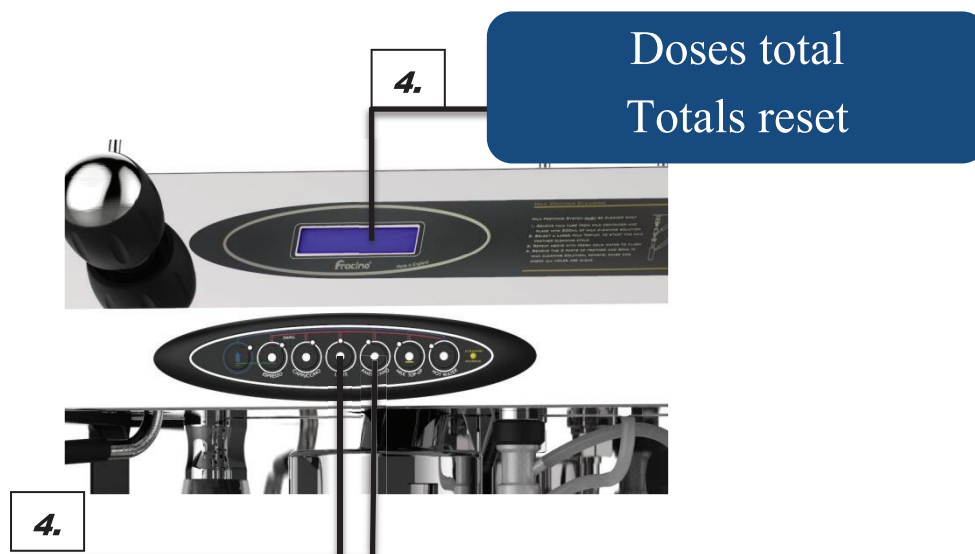

# MILK FROTHER ADJUSTMENT

## CAPPUCCINO AIR

1. The machine is fitted with a needle valve to adjust the amount of air entering the milk frothing system to account for variations in milk types and brands. The needle valve is located on the underside of the front panel, to the left of the group.

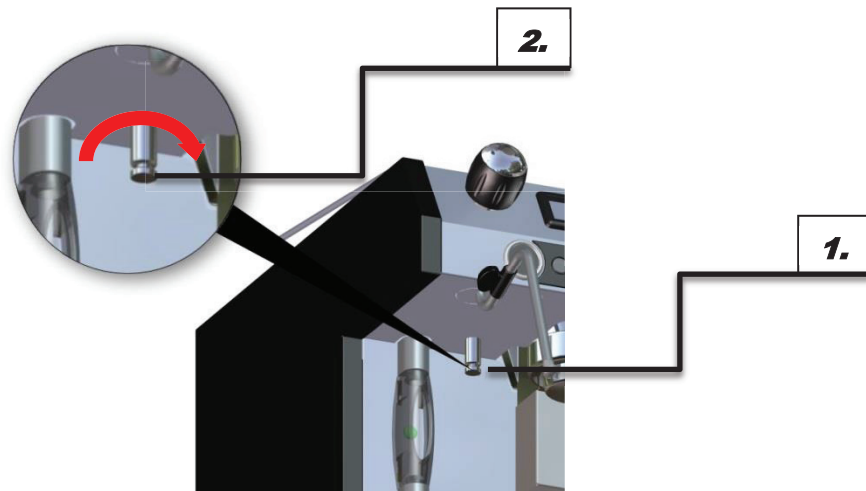

2. Turn the knob to the right to reduce the amount of air going in to the system, which will make a tighter foam.

**NOTE:** Closing the valve completely will prevent air entering the system, which will produce latte milk i.e. flat steamed milk.

3. Turning the valve to the left will open the valve allowing more air into the system which will make create foam with larger bubbles.

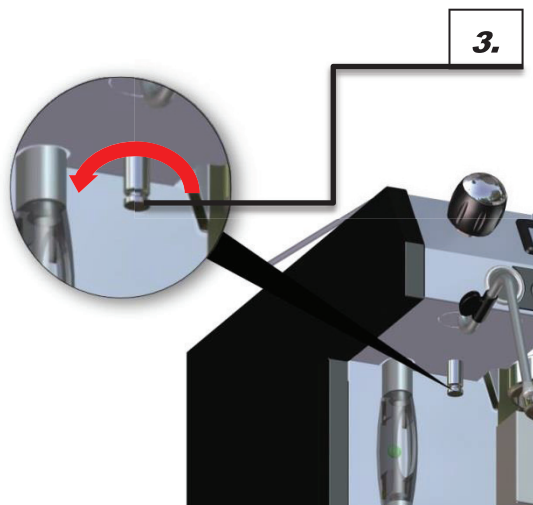

## ***STORAGE***

The machine must be stored and stored at a temperature above 5°C, to prevent water in the appliance freezing and causing damage.

**NOTE:** If the appliance has frozen or is suspected to have been stored at temperature below 5°C, the following procedures must be performed.

- 1.** The appliance must be fully isolated from the mains electricity and water supply.
- 2.** The appliance must be allowed to fully de-frost.
- 3.** All pipes, boiler, flow meter, manifold, group, solenoids and mains water inlet hose must be inspected for damage/leaks, if any parts are found to be damaged or leaking they must be replaced with new parts, it is recommended that a trained service engineer inspects and tests the appliance.
- 4.** If in doubt, contact Fracino to arrange for a trained service engineer to inspect and test the appliance.

## ***MAINTENANCE***

### ***SPECIAL PRECAUTIONS***



**WARNING:** Maintenance other than regular cleaning should only be performed by trained service engineers. Failure to use trained engineers may invalidate warranty and may damage the machine.

**WARNING:** Ensure the appliance has been fully isolated from the mains power supply before removing any body panels.

**WARNING:** Allow the machine to cool for at least an hour before removing any body panels or components.

**WARNING:** Ensure the boiler is fully de-pressurised by opening the steam valve(s)

## **WARNINGS**

- 1.** Ensure you fully read and understand this instruction manual before using the machine.
- 2.** At no time should body panels or parts be removed, unless by trained persons and only when the machine has been completely isolated from the mains power supply.
- 3.** Always treat the machine with respect, do not use if the machine has been dropped, vandalised or otherwise damaged, if in doubt contact your supplier or the Fracino Technical Advice line on 0906 906 666 (note calls to the advice line are chargeable at £1 per minute).
- 4.** Do not allow unqualified personnel to tamper with your machine.
- 5.** Your machine should have a regular service. The usage and hardness of water in your area will determine regularity (minimum once a year). It is essential that a water treatment unit be fitted in hard water areas to minimise the build up of scale.
- 6.** Care should be taken when making drinks, coffee, milk and hot water from the machine are hot and can scald – do not hold cups when drinks are being dispensed.
- 7.** Do not operate the machine without adequate training.
- 8. It is your responsibility to have a boiler test certificate carried out annually. This is a requirement of the HSE under the PSSR Act of 2000. Contact Fracino or an authorised service agent for further information or to have your boiler tested.**
- 9.** If the supply cord or plug is damaged, it must be replaced by the manufacturer, its service agent or similarly qualified persons in order to avoid a hazard.
- 10.** Children should be supervised to ensure they do not use or play with the machine.
- 11.** Coffee machines are heavy, take care when lifting or moving to avoid injury or damage to the machine.
- 12.** This appliance is not intended for use by persons (including children) with reduced physical, sensory or mental capabilities or lack experience or knowledge, unless they have been given supervision or instruction concerning the use of the appliance by a person responsible for their safety.
- 13.** The appliance must not be cleaned with a water jet, or located in an area where a water jet could be used.
- 14.** Disconnecting, by-passing, tampering or otherwise interfering with safety valves, high limit thermostats and pressure switches or other safety or control devices may cause serious injury to persons and/or serious damage to the machine.
- 15.** If the steam pressure gauge reads more than 1.5Bar, isolate the machine from the power and water supply, DO NOT use the machine until it has been inspected, tested and, if required, repaired by a suitably qualified engineer.
- 16.** If the pump/water pressure gauge reads more than 12Bar, isolate the machine from the power and water supply, DO NOT use the machine until it has been inspected, tested and, if required, repaired by a suitably qualified engineer.

# WARRANTY

## TERMS AND CONDITIONS

- 1.** Fracino coffee machines are guaranteed to be free from defects in material and workmanship during manufacture for a period of 12 months from the initial installation.
- 2.** Liability under the warranty is limited at the option of the manufacturer to the replacement or repair, free of charge, of such parts as shall be acknowledged after manufacturers inspection to be defective in material or workmanship, providing that any such claims under this warranty are notified to the manufacturer without delay. All parts recognised as defective shall become the property of the manufacturer.
- 3.** Except in so far as any injury, damage or loss is caused by the negligence of the manufacturer or its employees and in so far as exclusion is not prohibited or neglected by law this warranty is in substitution for any express or implied guarantee, representation warranty or condition and the manufacturer shall not be liable for any injury, damage or loss directly or indirectly attributed to any or done in connection herewith.
- 4.** The unexpired part of this warranty may be transferred to another owner providing the machine has been serviced and maintained by the manufacturer or manufacturers authorised service agent as prescribed and remains in the same location.
- 5.** The warranty shall cease immediately if:
  - a. The machine is modified or added to in anyway not previously agreed with the manufacturer in writing including fitting of non-genuine parts.
  - b. The instructions contained in the instruction manual are not complied with.
  - c. The machine is installed, serviced, relocated or maintained by anyone other than the manufacturer or manufacturers authorised service agent.
- 6.** The warranty does not cover items that require replacement in the course of maintenance or as a result of fair wear and tear. Nor does it cover limescale related faults.
- 7.** Kindly observe the following in your best interests:
  - a. We recommend using only Fracino original parts explicitly approved by the manufacturer. These parts have been selected for their reliability and suitability for Fracino machines.
  - b. We are unable to make assessments for other product parts and therefore cannot be held responsible for them, even if in individual cases an official approval or authorisation by governmental or approval agencies exist.
  - c. Fracino original parts as approved can be obtained from the factory. Comprehensive assistance and advice on maintaining your machine at its optimum level can be obtained from Fracino by calling the Technical Advice Line on 0906 906 666 (note calls to this line are chargeable at £1 per minute) or visiting the Fracino website – [www.fracino.com](http://www.fracino.com)
- 8.** We at Fracino wish you many years of satisfaction with your new coffee machine. Please keep this warranty and user manual in a safe place once you have read the important instructions contained herein and keep for future reference.

## ITEMS NOT COVERED BY WARRANTY

- 1.** Limescale – any calls to breakdown caused by scale related faults.
- 2.** Misuse/breakages – any calls being made as a result of accident, neglect or operator malpractice, and any other calls for, or as result of equipment relocation. NB: this also applies to over tightened steam and water valve handles
- 3.** Coffee and drink volumes – any calls to alter the programming of coffee or drinks after initial installation.
- 4.** Blocked waste – any calls due to the waste pipe being blocked. This is generally caused by grouts being flushed through the drip tray or poor plumbing.
- 5.** Blocked steam tube nozzle – any calls for “no steam” caused by the outlet holes on the steam tube nozzle not being cleaned.
- 6.** Blocked groups – any calls to “no water/coffee coming through group” caused by groups not being cleaned, incorrectly cleaned (including using cleaning powders or tablets to clean group), limescale, over filling filter holder with coffee, grinding coffee too fine, over tamping coffee or using a blank or blocked filter basket.
- 7.** Coffee flow – any calls related to “coffee flowing from group too fast” as a result of incorrectly ground coffee, incorrect tamping pressure or too little coffee being used in filter holder.



- 8.** Milk frother – any calls related to “milk frother not frothing” caused by incorrectly cleaning frother, incorrect assembly (including loss of o-rings) and wear of the o-rings.
- 9.** Milk frother – any calls related to milk temperature or milk foam consistency as a result of incorrectly adjustment of temperature or air valve, incorrectly assembled frother or incorrectly cleaning.
- 10.** Milk frother – any calls related to “milk not frothing” caused by stale milk or milk with high protein content.
- 11.** Grinders – the replacement of the grinder blades, any calls to reset portioning or coffee grind or to jammed/obstructed blades.
- 12.** Water treatment – any calls to replace a water treatment unit (DSU)
- 13.** Knockout drawers – any calls to repair jammed or broken runners as a result of negligence, malpractice or misuse by the operator.
- 14.** Training – Training on use and daily maintenance of the equipment is given at the time of installation. Any calls for further training or for training on a day other than that of installation will be fully chargeable.

## ***TECHNICAL SPECIFICATIONS***

***Voltage:*** 230Vac 50Hz

***Power rating:*** 2.7Kw

***Current rating:*** 13Amp

***Min. inlet water pressure:*** 1Bar (100kPa)

***Max. inlet water pressure:*** 6Bar (600kPa)

***Boiler max working pressure:*** 2Bar (200kPa)

***Boiler normal working pressure:*** 1.3Bar (130kPa)

***Boiler safety valve set pressure:*** 1.6 – 1.8Bar (160-180kPa)

***Expansion valve set pressure:*** 12Bar(1200kPa)

***Pump set pressure:*** 9Bar(900kPa)

***Boiler capacity:*** 7L

***Overall dimensions:*** 450 x 375 x 550mm (HxWxD)

***Weight:*** 35kg

## APPENDIX 1 – DRINK TIMES

|   |              | 8oz Cup          |         | 12oz Cup         |         | 16oz Cup         |         |
|---|--------------|------------------|---------|------------------|---------|------------------|---------|
|   |              | ESPRESSO VOLUME  |         | ESPRESSO VOLUME  |         | ESPRESSO VOLUME  |         |
| <b>ESPRESSO</b>                               |              | 35mL             | -       | 60mL             | -       | 75mL             | -       |
| <b>CAPPUCCINO</b>                             | STEAM TIME   | 35ml             | 24 sec  | 60mL             | 32 sec  | 75mL             | 45 sec  |
|   | COFFEE DELAY |                  | 3.0 sec |                  | 4.5 sec |                  | 4.5 sec |
| <b>LATTE</b>                                  | STEAM TIME   | 35mL             | 24 sec  | 60mL             | 45 sec  | 75mL             | 50 sec  |
|   | AIR DELAY    |                  | 2.5 sec |                  | 2.5 sec |                  | 2.5sec  |
|   | STEAM DELAY  |                  | 3.5 sec |                  | 3 sec   |                  | 5 sec   |
| <b>AMERICANO</b>                              | WATER TIME   | 35mL             | 4.0 sec | 60mL             | 6 sec   | 75mL             | 8 sec   |
|   | COFFEE DELAY |                  | 3.0 sec |                  | 4 sec   |                  | 7 sec   |
| <b>SMALL MILK TOP UP</b>                      | STEAM TIME   | -                | 8sec    | -                | 10sec   | -                | 12sec   |
| <b>LARGE MILK TOP UP*<br/>(MILK CLEANING)</b> | STEAM TIME   | -                | 60 sec  | -                | 60 sec  | -                | 60 sec  |
|   | AIR DELAY    |                  | 15 sec  |                  | 15 sec  |                  | 15 sec  |
|   |              | HOT WATER VOLUME |         | HOT WATER VOLUME |         | HOT WATER VOLUME |         |
| <b>HOT WATER</b>                              |              | 230mL            |         | 300mL            |         | 360mL            |         |

**NOTE:** The drink settings stated above are suggested settings only, it is the responsibility and judgement of the user/owner to ensure the drinks are to the required quality, taste, consistency, appearance and cup level, this depends on a number of factors such as individual taste, type of coffee etc....

**NOTE:** The machine can be set to dispense 2 sizes of drinks, for example 8oz and 12oz, where the 12oz would be selected using the large button before selecting the drink.

**\*NOTE:** The Large Milk Top-up/milk cleaning settings should not be modified as these are the optimal settings to clean the milk frother.



V.2.1



**Fracino** Birch Road East, Birmingham, B6 7DB, Great Britain.  
Website / [www.fracino.com](http://www.fracino.com) Email / [sales@fracino.com](mailto:sales@fracino.com)  
Tel / +44 (0)121 328 5757 Fax / +44 (0)121 327 3333

The Fracino company policy is one of continuous improvement. We retain the right to change specification without prior notice.